

# Tracktronics Australia

Electronics Engineering & Manufacturing  
46 Leray Rd, Elimbah QLD 4516  
Phone 07 5497 4384  
<http://www.tracktronics.com.au>

ABN 64 078 631 688  
ACN 078 631 688  
Fax 07 5497 4656  
Email [enquire@tracktronics.com.au](mailto:enquire@tracktronics.com.au)

## Product Specification

### Fibre Optic Modem Set 1 - 4 ports RS232 / RS422 / RS485 Interface

Rev F

4 February, 2004

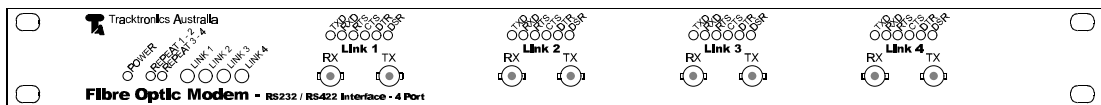

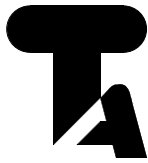

# Tracktronics Australia

Electronics Engineering & Manufacturing  
46 Leray Rd, Elimbah QLD 4516  
Phone 07 5497 4384  
<http://www.tracktronics.com.au>

ABN 64 078 631 688  
ACN 078 631 688  
Fax 07 5497 4656  
Email [enquire@tracktronics.com.au](mailto:enquire@tracktronics.com.au)

## Table of Contents

<b>1. ABSTRACT</b>	<b>4</b>
<b>2. INTRODUCTION</b>	<b>4</b>
<b>3. DESCRIPTION</b>	<b>5</b>
<b>3.1 Unit Block Diagram</b>	<b>5</b>
<b>3.2 Modes of Operation</b>	<b>6</b>
3.2.1 Point to Point Communications	6
3.2.2 Drop and Repeat Communications	6
<b>3.3 Brief Overview of Front and Back panels</b>	<b>8</b>
<b>3.4 User Configuration</b>	<b>9</b>
<b>3.5 Visual Diagnostics</b>	<b>10</b>
3.5.1 General Diagnostic LED's	10
3.5.2 Serial Diagnostic LED's	11
<b>4. SPECIFICATIONS</b>	<b>12</b>
<b>4.1 Power Supply</b>	<b>12</b>
4.1.1 AC Supply Option	12
4.1.2 DC Supply Options	12
<b>4.2 Fibre Optic Ports</b>	<b>13</b>
<b>4.3 RS232 Ports</b>	<b>14</b>
<b>4.4 RS422 / RS485 Ports</b>	<b>15</b>
<b>4.5 Link Fail Relay Ports</b>	<b>16</b>
<b>4.6 Layout &amp; Size</b>	<b>17</b>
4.6.1 Size	17
4.6.2 Front Panel Layout	17
4.6.3 Rear Panel Layout	17
<b>4.7 Environmental Conditions</b>	<b>17</b>
<b>5. PRODUCT PART NUMBERS</b>	<b>18</b>
<b>5.1 Standard Unit Configuration - RS422 compatible ports</b>	<b>18</b>
<b>5.2 Optional Unit Configuration - RS485 compatible ports</b>	<b>18</b>
<b>5.3 Optional Unit Configuration - Single-mode Fibre modems</b>	<b>18</b>

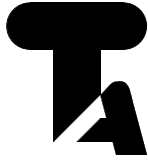

## **Tracktronic Australia**

---

Electronics Engineering & Manufacturing  
46 Leray Rd, Elimbah QLD 4516  
Phone 07 5497 4384  
<http://www.tracktronics.com.au>

ABN 64 078 631 688  
ACN 078 631 688  
Fax 07 5497 4656  
Email [enquire@tracktronics.com.au](mailto:enquire@tracktronics.com.au)

### **5.4 Power Supply Options**

**18**



## Tracktronics Australia

Electronics Engineering & Manufacturing  
46 Leray Rd, Elimbah QLD 4516  
Phone 07 5497 4384  
<http://www.tracktronics.com.au>

ABN 64 078 631 688  
ACN 078 631 688  
Fax 07 5497 4656  
Email [enquire@tracktronics.com.au](mailto:enquire@tracktronics.com.au)

## 1. Abstract

This specification provides details of the Fibre Optic Modem unit developed by Tracktronics Australia Pty Ltd.

## 2. Introduction

The Fibre Optic Modem Set is a 19" rack-mounted, self-contained set of 4 modem ports which can provide full duplex synchronous or asynchronous communications over a duplex optical fibre cable.

The unit's serial interface can support both RS232 or RS422 / RS485 signal levels, with 2 separate RJ45 connectors (RS232 and RS422 / RS485 provided for each modem port).

Each modem port is capable of transferring one pair of data signals, and 2 pairs of handshaking signals with data rates between DC and 20 kbps. Each port operates with all commonly available multi-mode fibres over at least 5 km. A model is also available for operation over at least 40km of single mode fibre.

In addition to providing a standard point-to-point modem capability, the Modem Set has a special feature to be able to provide a Drop and Repeat serial communications ability.

The Drop and Repeat configuration allows a multi-drop communications system to be easily emulated using point-to-point fibre communications. The Drop and Repeat configuration, which is also commonly denoted as a Combiner / Splitter configuration, is commonly utilised in SCADA installations, and allows a single communications master unit to communicate with multiple slave units with a minimum of fibre optic resources.

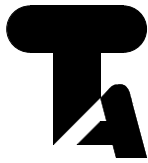

# Tracktronics Australia

Electronics Engineering & Manufacturing  
46 Leray Rd, Elimbah QLD 4516  
Phone 07 5497 4384  
<http://www.tracktronics.com.au>

ABN 64 078 631 688  
ACN 078 631 688  
Fax 07 5497 4656  
Email [enquire@tracktronics.com.au](mailto:enquire@tracktronics.com.au)

## 3. Description

### 3.1 Unit Block Diagram

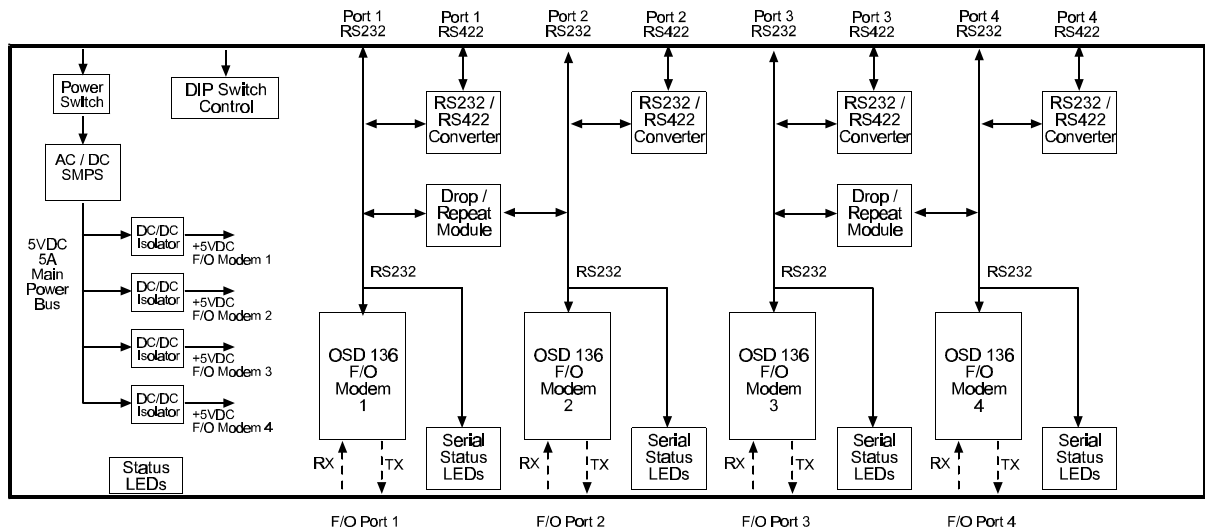
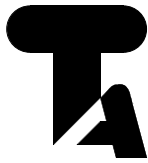

Figure 3-1 Unit Block Diagram



## Tracktronics Australia

Electronics Engineering & Manufacturing  
46 Leray Rd, Elimbah QLD 4516  
Phone 07 5497 4384  
<http://www.tracktronics.com.au>

ABN 64 078 631 688  
ACN 078 631 688  
Fax 07 5497 4656  
Email [enquire@tracktronics.com.au](mailto:enquire@tracktronics.com.au)

### 3.2 Modes of Operation

#### 3.2.1 Point to Point Communications

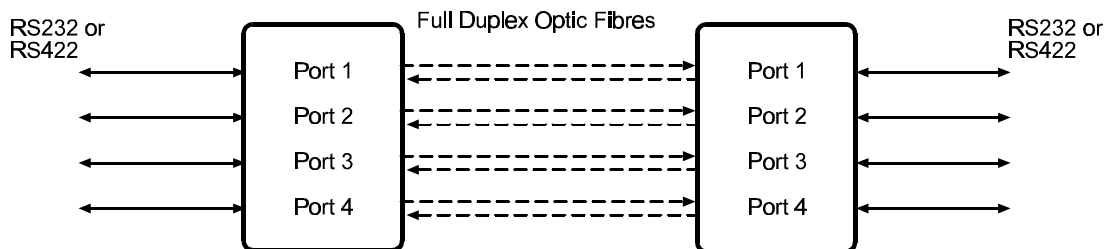

**Figure 3-1** Point to Point Communications Block Diagram

Point to Point communications is the simplest and most common application of a modem set. It involves a full-duplex serial connection from the port of one modem set to a corresponding port on another modem set. Figure 3-1 above shows an example of a Point to Point communications system.

#### 3.2.2 Drop and Repeat Communications

The basic concept of Drop and Repeat Communications is that communications from a preceding Modem Set is echoed out the local RS232 / RS422 port, before being re-transmitted to the following Modem Set. In addition, the communications from the following Modem Set is combined with the local RS232 / RS422 received data before being transmitted back to the preceding Modem Set.

Figure 3-2 below shows a system diagram of the communications paths when the Drop and Repeat function has been enabled. Note that for figure simplicity, only the communications paths for Links 1 and 2 are shown. In practice, Links 3 and 4 can also be configured for either Point to-Point or Drop and Repeat functionality.

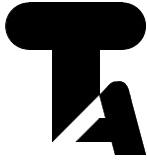

# Tracktronics Australia

Electronics Engineering & Manufacturing  
46 Leray Rd, Elimbah QLD 4516  
Phone 07 5497 4384  
<http://www.tracktronics.com.au>

ABN 64 078 631 688  
ACN 078 631 688  
Fax 07 5497 4656  
Email [enquire@tracktronics.com.au](mailto:enquire@tracktronics.com.au)

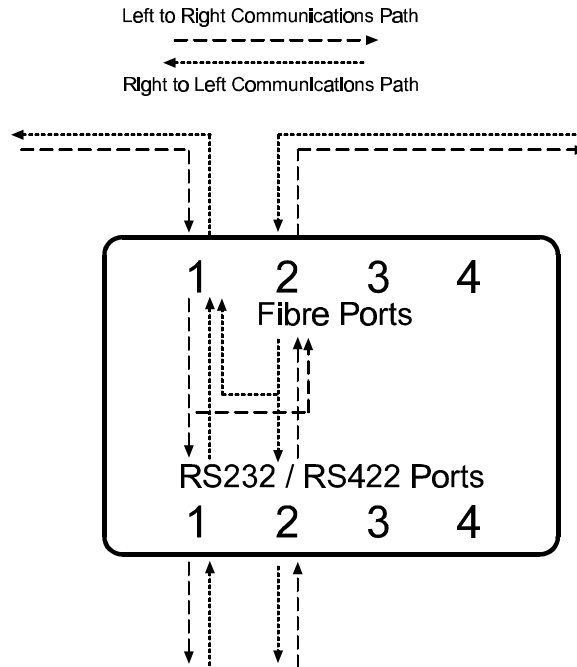

**Figure 3-2** Drop and Repeat Communications Block Diagram

The Drop and Repeat capability allows a single Master - multiple Slave communications system to be easily established with a minimum of effort.

Figure 3-3 below shows an example configuration required for a system based on a Master - 2 Slave communications system.

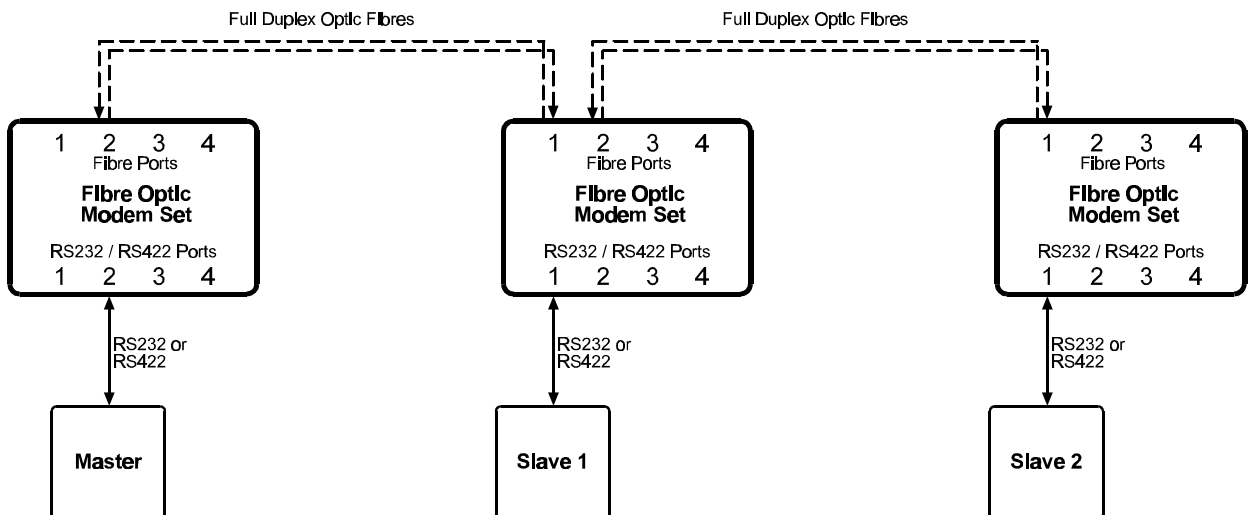

**Figure 3-3** Example of a Drop and Repeat Communications System

Communications transmitted from the Master will be echoed to both Slave units, and communications from the Slave units will be combined together and transmitted back to the Master unit.

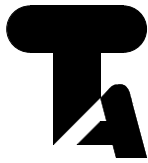

# Tracktronics Australia

Electronics Engineering & Manufacturing  
46 Leray Rd, Elimbah QLD 4516  
Phone 07 5497 4384  
<http://www.tracktronics.com.au>

ABN 64 078 631 688  
ACN 078 631 688  
Fax 07 5497 4656  
Email [enquire@tracktronics.com.au](mailto:enquire@tracktronics.com.au)

## 3.3 Brief Overview of Front and Back panels

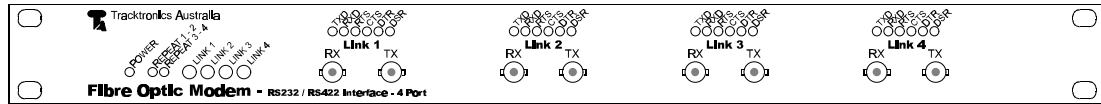

Figure 3-4 View of Front Panel

The Front panel provides:

- Diagnostic LED's
- Fibre Optic connectors

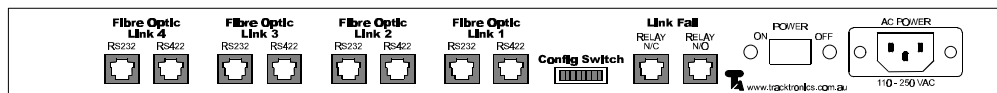
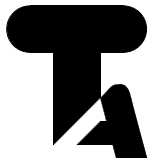

Figure 3-5 View of Rear Panel

The Rear Panel provides:

- Power connector (\* Note that a phoenix 3-pin power connector will be substituted for the IEC power connector on the DC supply models).
- Link Fail Alarm relay connector
- Configuration switch
- RS232 port connectors
- RS422 port connectors



## Tracktronics Australia

Electronics Engineering & Manufacturing  
46 Leray Rd, Elimbah QLD 4516  
Phone 07 5497 4384  
<http://www.tracktronics.com.au>

ABN 64 078 631 688  
ACN 078 631 688  
Fax 07 5497 4656  
Email [enquire@tracktronics.com.au](mailto:enquire@tracktronics.com.au)

### 3.4 User Configuration

A 8-way piano dip switch on the rear panel provides the only user configuration required for an installation.

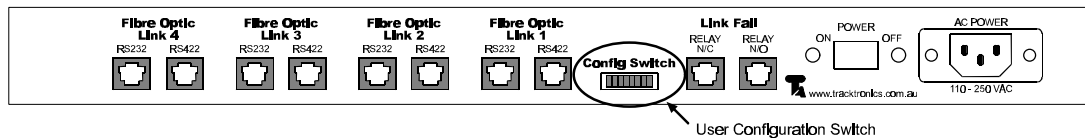

Figure 3-6 View of Rear Panel Configuration Switch

Position 1     **Fibre Optic Link 1 Enable** - when set to ON, the power supply and system diagnostics for Link 1 modem will be enabled.

Position 2     **Fibre Optic Link 2 Enable** - when set to ON, the power supply and system diagnostics for Link 2 modem will be enabled.

Position 3     **Fibre Optic Link 3 Enable** - when set to ON, the power supply and system diagnostics for Link 3 modem will be enabled.

Position 4     **Fibre Optic Link 4 Enable** - when set to ON, the power supply and system diagnostics for Link 4 modem will be enabled.

Position 5     **Drop and Repeat Enable for Modems 1 and 2** - when set to ON, the Drop and Repeat feature will be enabled for Links 1 and 2.

Position 6     **Drop and Repeat Enable for Modems 3 and 4** - when set to ON, the Drop and Repeat feature will be enabled for Links 3 and 4.

Position 7     **Spare** - reserved for future use.

Position 8     **Spare** - reserved for future use.

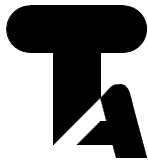

# Tracktronics Australia

Electronics Engineering & Manufacturing  
46 Leray Rd, Elimbah QLD 4516  
Phone 07 5497 4384  
http://www.tracktronics.com.au

ABN 64 078 631 688  
ACN 078 631 688  
Fax 07 5497 4656  
Email [enquire@tracktronics.com.au](mailto:enquire@tracktronics.com.au)

## 3.5 Visual Diagnostics

The Modem Set visual diagnostics consists of:

- General Diagnostic LED's
- Serial Diagnostics LED's

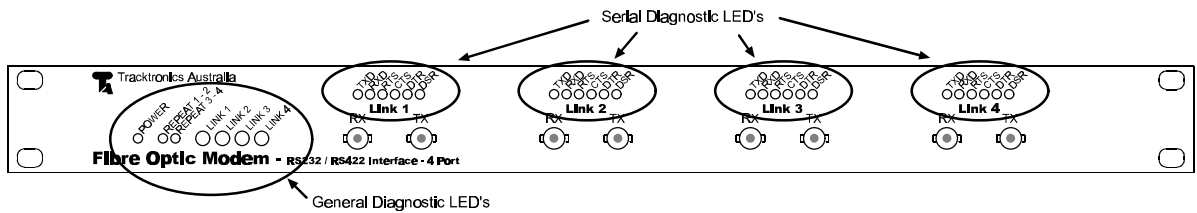

Figure 3-7 View of Front Panel Diagnostic LED's

### 3.5.1 General Diagnostic LED's

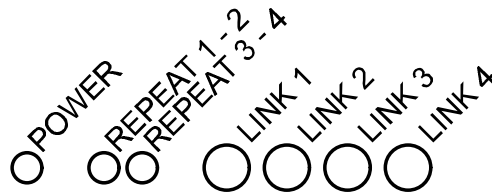
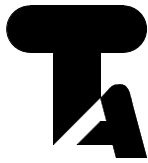

Figure 3-8 View of General Diagnostic LED's

Power	Green 3mm LED	Indicates presence of incoming power supply.
Repeat 1 - 2	Green 3mm LED	Indicates that Drop and Repeat feature for Links 1 & 2 has been activated via the rear panel config switch.
Repeat 3 - 4	Green 3mm LED	Indicates that Drop and Repeat feature for Links 3 & 4 has been activated via the rear panel config switch.
Link 1	Tricolour 5mm LED	See Link LED description below.
Link 2	Tricolour 5mm LED	See Link LED description below.
Link 3	Tricolour 5mm LED	See Link LED description below.
Link 4	Tricolour 5mm LED	See Link LED description below.

#### Link LED description

The Link LED is a tricolour LED capable of displaying 3 colours - Red, Yellow and Green:



## Tracktronics Australia

Electronics Engineering & Manufacturing  
46 Leray Rd, Elimbah QLD 4516  
Phone 07 5497 4384  
<http://www.tracktronics.com.au>

ABN 64 078 631 688  
ACN 078 631 688  
Fax 07 5497 4656  
Email [enquire@tracktronics.com.au](mailto:enquire@tracktronics.com.au)

Off	Link modem has been manually disabled by user, else loss of main +5 VDC supply.
Red	Link modem's internal DC - DC supply isolator has failed.
Yellow	Link modem has detected a loss of the incoming fibre signal.
Green	Link is operating correctly (normal operation state).

### 3.5.2 Serial Diagnostic LED's

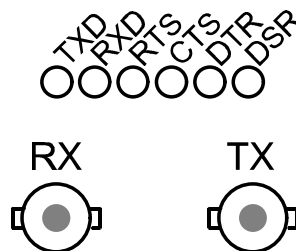

**Figure 3-9** View of Serial Diagnostic LED's

TXD	Yellow 3mm LED	Transmit Data
RXD	Yellow 3mm LED	Receive Data
RTS	Yellow 3mm LED	Request To Send
CTS	Yellow 3mm LED	Clear To Send
DTR	Yellow 3mm LED	Data Terminal Ready
DSR	Yellow 3mm LED	Data Set Ready

Note that the Serial Diagnostic LED's will flash in correspondence with data activity on the signal line.

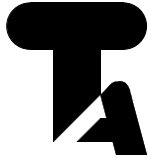

## Tracktronics Australia

Electronics Engineering & Manufacturing  
46 Leray Rd, Elimbah QLD 4516  
Phone 07 5497 4384  
<http://www.tracktronics.com.au>

ABN 64 078 631 688  
ACN 078 631 688  
Fax 07 5497 4656  
Email [enquire@tracktronics.com.au](mailto:enquire@tracktronics.com.au)

## 4. Specifications

### 4.1 Power Supply

#### 4.1.1 AC Supply Option

110 - 240VAC 50 - 60Hz universal AC input, 25W maximum.

The AC Supply option uses an IEC style 3 pin socket as the power supply input, and a compatible plug with 2 metre lead and 3-pin GPO plug is supplied with each unit.

#### 4.1.2 DC Supply Options

12VDC nominal (9 - 18VDC) 25W maximum

24VDC nominal (18 - 36VDC) 25W maximum

48VDC nominal (36 - 72VDC) 25W maximum

The DC Supply option uses a 3 terminal phoenix socket as the power supply input, and a compatible phoenix plug is supplied with each unit.

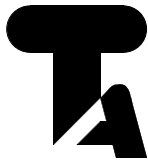

# Tracktronics Australia

Electronics Engineering & Manufacturing  
46 Leray Rd, Elimbah QLD 4516  
Phone 07 5497 4384  
<http://www.tracktronics.com.au>

ABN 64 078 631 688  
ACN 078 631 688  
Fax 07 5497 4656  
Email [enquire@tracktronics.com.au](mailto:enquire@tracktronics.com.au)

## 4.2 Fibre Optic Ports

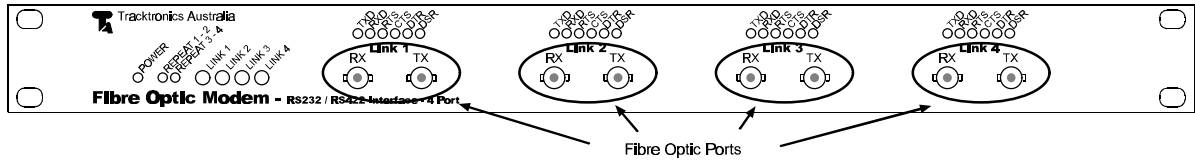

Figure 4-1 View of Fibre Optic Ports

### Connectors

ST standard, SMA optional

### Transmit Power

- > -23dBm (5uW) average into single-mode fibre (single-mode option only)
- > -23dBm (5uW) average into 50/125 multi-mode fibre
- > -20dBm (10uW) average into 62.5/125 multi-mode fibre

### Receiver Sensitivity

< -43dBm (50nW) average

### Optical Wavelength

850nm nominal (standard unit for multi-mode fibre)

1300nm nominal (single-mode fibre option)

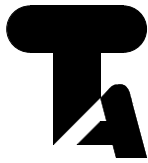

# Tracktronics Australia

Electronics Engineering & Manufacturing  
46 Leray Rd, Elimbah QLD 4516  
Phone 07 5497 4384  
<http://www.tracktronics.com.au>

ABN 64 078 631 688  
ACN 078 631 688  
Fax 07 5497 4656  
Email [enquire@tracktronics.com.au](mailto:enquire@tracktronics.com.au)

## 4.3 RS232 Ports

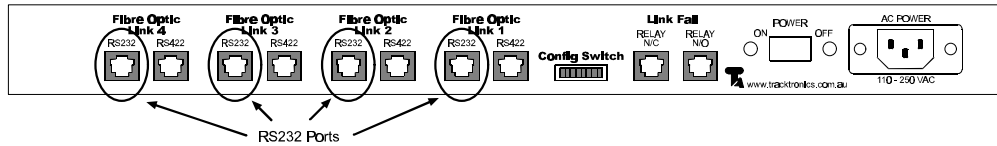

Figure 4-2 View of RS232 Ports

### Connector

RJ45 8P8C Socket

Pin	Signal	Direction for Modem Set
1	*Data Set Ready	Output
2	Request To Send	Input
3	Chassis Ground	
4	Transmit Data	Input
5	Receive Data	Output
6	Signal Ground	
7	Clear To Send	Output
8	Data Terminal Ready	Input

\* pin 1 may also be used for Data Carrier Detect in certain applications.

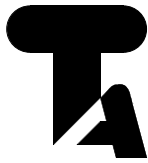

# Tracktronics Australia

Electronics Engineering & Manufacturing  
46 Leray Rd, Elimbah QLD 4516  
Phone 07 5497 4384  
<http://www.tracktronics.com.au>

ABN 64 078 631 688  
ACN 078 631 688  
Fax 07 5497 4656  
Email [enquire@tracktronics.com.au](mailto:enquire@tracktronics.com.au)

## 4.4 RS422 / RS485 Ports

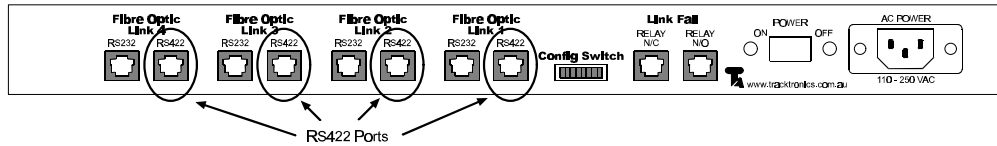
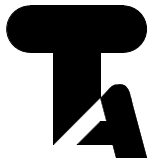

Figure 4-3 View of RS422 / RS485 Ports

### Connector

RJ45 8P8C Socket

Pin	Signal	Direction for Modem Set
1	Request To Send +	Input
2	Request To Send -	Input
3	Receive Data +	Output
4	Transmit Data -	Input
5	Transmit Data +	Input
6	Receive Data -	Output
7	Clear To Send +	Output
8	Clear To Send -	Output



# Tracktronics Australia

Electronics Engineering & Manufacturing  
46 Leray Rd, Elimbah QLD 4516  
Phone 07 5497 4384  
<http://www.tracktronics.com.au>

ABN 64 078 631 688  
ACN 078 631 688  
Fax 07 5497 4656  
Email [enquire@tracktronics.com.au](mailto:enquire@tracktronics.com.au)

## 4.5 Link Fail Relay Ports

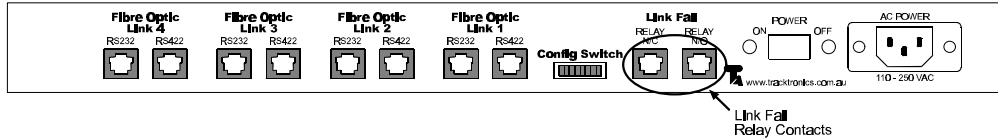

Figure 4-4 View of Link Fail Relay Ports

### Connector

RJ45 8P8C Socket

<u>Pin</u>	<u>Signal</u>
1	Link 1 Fail Common
2	Link 1 Fail Contact
3	Link 2 Fail Common
4	Link 2 Fail Contact
5	Link 3 Fail Common
6	Link 3 Fail Contact
7	Link 4 Fail Common
8	Link 4 Fail Contact

### Link Fail N/C Relay Port

Link Fail Common and Contact will open if the Link is fully operational and enabled.

### Link Fail N/O Relay Port

Link Fail Common and Contact will short together if the Link is fully operational and enabled.

### Contact Rating

50Vdc, 0.5 Amp maximum, continuous. 200Vdc galvanic isolation.

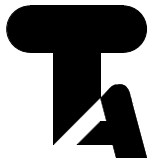

# Tracktronics Australia

Electronics Engineering & Manufacturing  
46 Leray Rd, Elimbah QLD 4516  
Phone 07 5497 4384  
<http://www.tracktronics.com.au>

ABN 64 078 631 688  
ACN 078 631 688  
Fax 07 5497 4656  
Email [enquire@tracktronics.com.au](mailto:enquire@tracktronics.com.au)

## 4.6 Layout & Size

### 4.6.1 Size

1RU high by 19" rack mount, approx. 250 mm in depth.

### 4.6.2 Front Panel Layout

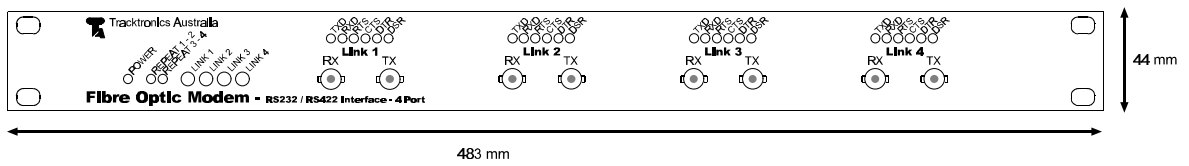

Figure 4-5 Front Panel Layout showing approximate size

### 4.6.3 Rear Panel Layout

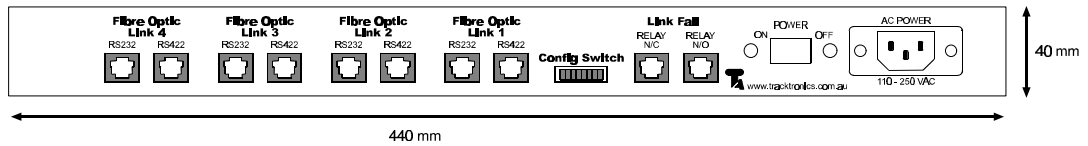
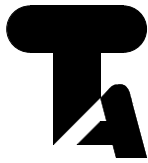

Figure 4-6 Rear Panel Layout showing approximate size

## 4.7 Environmental Conditions

Operating Temperature	0degC to 60degC
Relative Humidity	0 to 95% non-condensing



## Tracktronics Australia

Electronics Engineering & Manufacturing  
46 Leray Rd, Elimbah QLD 4516  
Phone 07 5497 4384  
<http://www.tracktronics.com.au>

ABN 64 078 631 688  
ACN 078 631 688  
Fax 07 5497 4656  
Email [enquire@tracktronics.com.au](mailto:enquire@tracktronics.com.au)

## 5. Product Part Numbers

### 5.1 Standard Unit Configuration - RS422 compatible ports

TA Part Number	Unit Description
0200-000-xxx	4 ports RS232 / RS422 (inc. 4 OSD136 modems)
0200-001-xxx	4 ports RS232 / RS422 (inc. 1 OSD136 modems)
0200-002-xxx	4 ports RS232 / RS422 (inc. 2 OSD136 modems)
0200-003-xxx	4 ports RS232 / RS422 (inc. 3 OSD136 modems)
0200-010-xxx	4 ports RS232 / RS422 (customer supplied OSD136 modems)

### 5.2 Optional Unit Configuration - RS485 compatible ports

TA Part Number	Unit Description
0200-100-xxx	4 ports RS232 / RS485 (inc. 4 OSD136 modems)
0200-101-xxx	4 ports RS232 / RS485 (inc. 1 OSD136 modems)
0200-102-xxx	4 ports RS232 / RS485 (inc. 2 OSD136 modems)
0200-103-xxx	4 ports RS232 / RS485 (inc. 3 OSD136 modems)
0200-110-xxx	4 ports RS232 / RS485 (customer supplied OSD136 modems)

### 5.3 Optional Unit Configuration - Single-mode Fibre modems

TA Part Number	Unit Description
0200-x04-xxx	4 ports RS232 / RS485 (inc. 4 OSD136 modems)
0200-x05-xxx	4 ports RS232 / RS485 (inc. 1 OSD136 modems)
0200-x06-xxx	4 ports RS232 / RS485 (inc. 2 OSD136 modems)
0200-x07-xxx	4 ports RS232 / RS485 (inc. 3 OSD136 modems)
0200-x10-xxx	4 ports RS232 / RS485 (customer supplied OSD136 modems)

### 5.4 Power Supply Options

The part number suffix refers to the power supply option required.

TA Part Number	Unit Description
0200-xxx-12D	12VDC nominal (9 - 18Vdc input) 25W max. (standard)
0200-xxx-24D	24VDC nominal (18 - 36Vdc input) 25W max.
0200-xxx-48D	48VDC nominal (36 - 72Vdc input) 25W max.
0200-xxx-240A	110-240VAC nominal (90 - 250Vac input) 25W max.